

brother

# BT30 刀柄 TOOLING SYSTEM

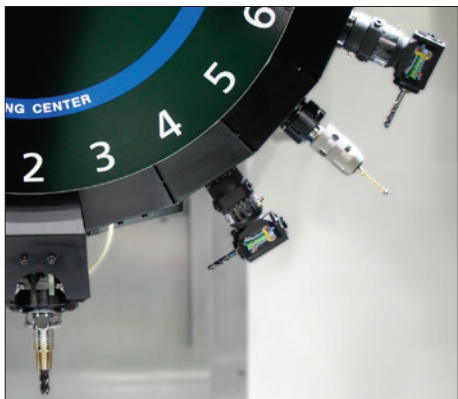

## DETa-1

P.2

DETa-1 超弹性筒夹刀柄

DETa-1 COLLET HOLDER



## 袖珍型角度头

P.10

ANGLE HEAD **HALF**

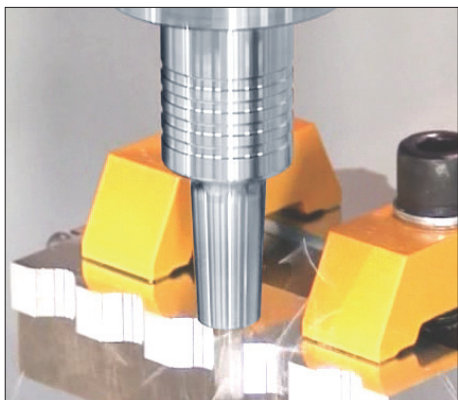

## 小型加工中心

Compact machining center

# SPEEDIO

### 压倒性的高效率

Overwhelming high productivity

### 更高水准的加工能力

One-rank higher machining capabilities

### 机电一体开发实现最优化控制

Better usability through machine/controller integrated development

### 最高等级的节能环保性能

Top-level environmental performance



## 热装式刀柄

P.4

# SLIMLINE

SHRINK-FIT HOLDER

# SLIMLINE



日本恩司迪公司  
**MST** corporation

2402

# DETa-1 超弹性筒夹刀柄

# DETa-1 COLLET HOLDER

## DETa-1

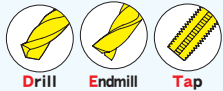

### DTA

φ0.5 ~ 13

操作简单  
Easy operation

### DTB

φ0.5 ~ 13

高转速规格  
高性价比  
For high-speed cutting  
Highly cost-effective

### DTE

φ1 ~ 13

对应中心通冷  
Available for using coolant through

过盈量 2mm  
Collapsibility

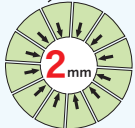

### DTA

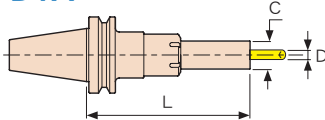

### DTB

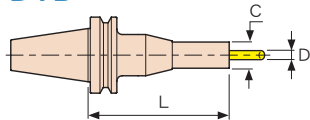

### DTE

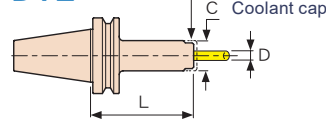

CODE	φD	L	φC	kg	Icon
<b>BT30-DTA 3- 90</b>	0.5 ~ 3.175	90	10	0.5	D 3
-DTA 7- 90	1 ~ 7	120	21	0.7	D 7
-120					
-DTA12-120					
<b>BT30-DTB 3- 90</b>	0.5 ~ 3.175	90	10	0.6	D 3
-DTB 7- 75	1 ~ 7	75	21	0.5	D 7
-105					
-DTB12- 75					
-105	2.5 ~ 13	105	0.7		
<b>BT30-DTE 7- 60-MAS2</b>	1 ~ 7	60	29	0.6	D 7
-DTE12- 75-MAS2	2.5 ~ 13	75	40	0.9	D12

- 选购品
  - DETa-1 超弹性弹簧筒夹
  - 扳手·六角扳手
  - 拉钉 → P.12
  - 清洁用具 毛毡型
- 标准附属品
  - 导向拉杆 (DTA3)
  - 拉钉 (DTE)
- 备考
  - DTB12型的拉钉 (P-535) 为后拉螺栓一体型专用拉钉。拧紧时请选用市售的单口扳手 (13mm)
  - DTE型附带有专用拉钉。拧紧时请使用市售的单口扳手 (13mm) 如需更换拉钉请事先垂询弊司。
  - DTE型刀柄使用内冷功能所需零部件,另请垂询敝司。
- Option
  - DETa-1 Collet
  - Spanner Wrench
  - Retention knob → P. 12
  - Cleaning tool felt type
- Std. Access.
  - Rod (DTA3)
  - Retention knob (DTE)
- Note
  - DTB12 requires the dedicated retention knob (P-535), which has the feature of draw bolt. Please use a commercially available 13mm single-ended wrench.
  - DTE comes with the dedicated retention knob. Please use a commercially available 13mm single-ended wrench. Contact us for exchanging the retention knob.
  - For parts compatible with coolant-through for DTE type, please contact us.

## DETa-1 超弹性筒夹刀柄

## DETa-1 collet



CODE		φD
标准级 Standard collet	超精密级 (P级) Precision collet	
D 3- 0.6	请在标准级编码的末尾追加“-P”。 Add “-P” after the standard type item code.  < 例 /ex.> D12-6-P	0.5 ~ 0.6
- 0.8		0.6 ~ 0.8
- 1		0.8 ~ 1
- 1.5		1 ~ 1.5
- 2		1.5 ~ 2
- 2.5		2 ~ 2.5
- 3		2.5 ~ 3
- 3.175		2.7 ~ 3.175
D 7- 1.5		1 ~ 1.5
- 2		1.5 ~ 2
- 2.5		2 ~ 2.5
- 3		2.5 ~ 3
- 4		3 ~ 4
- 5	4 ~ 5	
- 6	5 ~ 6	
- 7	6 ~ 7	
D12- 4	2.5 ~ 4	
- 6	4 ~ 6	
- 8	6 ~ 8	
-10	8 ~ 10	
-12	10 ~ 12	
-13	11 ~ 13	

### 偏摆精度

### Run-out accuracy

筒夹 Collet	偏摆精度 (μm) Run-out accuracy (μm)	
	D3	D7/D12
超精密级 (P级) Precision collet	3 (6)	5 (10)
标准级 Standard Collet	5 (10)	10 (15)

※为筒夹的单体精度。( )内为利用过盈量后筒夹单体精度  
※ Accuracy of collet alone.  
( ) means collapsibility usable.

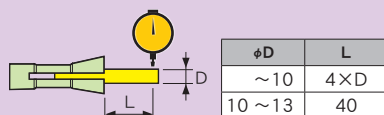

### 扳手·六角扳手

### Spanner·Wrench

CODE	刀柄型号 Holder type
F-22	DTA 3
-38	DTA 7
-45	DTA12
DW-2.5-110	DTB 3
TW-5	DTB 7



### 清洁用具 毛毡型 (DTA3 / DTB3)

### Cleaning tool felt type (DTA3 / DTB3)

请用于清洁刀柄内部。  
Used to clean the inside of holder.

CODE	数量 Q'ty
PCT01-10	10
-25	25

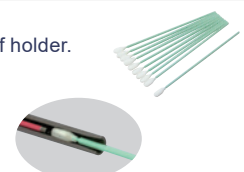

# 弹簧筒夹刀柄

# COLLET HOLDER

## CTH

φ2.4 ~ 20

高转速规格  
For high-speed cutting



## CTA

φ2.4 ~ 20

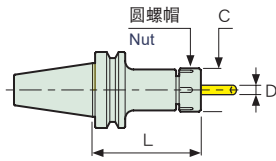

CODE	φD	L	φC	Kg	
<b>BT30-CTH10- 45</b>	2.4 ~ 10	45	36	0.5	C10-P
- 75		75			
<b>-CTH20- 60</b>	5.8 ~ 20	60	50	0.6	C20-P
- 90		90			
<b>BT30-CTA10- 45</b>	2.4 ~ 10	45	36	0.5	C10
- 75		75		0.7	
-105		105		0.9	
<b>-CTA20- 60</b>	5.8 ~ 20	60	50	0.6	C20
- 90		90		0.9	

- 选购品
  - 弹簧筒夹
  - 扳手
  - 可调节式扭矩扳手
  - 筒夹拔出器
  - 拉钉→P.12
- 标准附属品
  - 圆螺帽
- 备考
  - CTH型请务必使用P级弹簧筒夹。
- Option
  - Spring collet
  - Spanner
  - Retention knob→ P.12
  - Adjustable torque wrench
  - Collet remover
- Std. Access.
  - Nut
- Note
  - Be sure to use precision type spring collet.(CTH)

## 弹簧筒夹

## Spring collet

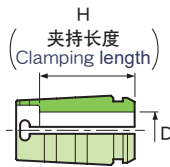
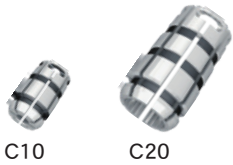

CODE		φD	过盈量 Collapsibility	H
标准级 Standard collet	超精密级(P级) Precision collet			
<b>C10-D</b>	请在标准级编码的末尾追加“-P”。 Add“-P”after the standard type item code. (例 /ex.) <b>C10-6-P</b>	2.6 2.8 3 3.2 3.4 ...0.2间隔... ...0.2 STEPS... 9.4 9.6 9.8 10	0.2	D= 2.6~ 5.8 → 18 6 ~10 → 20
<b>C20-D</b>		6 6.2 6.4 6.6 6.8 ...0.2间隔... ...0.2 STEPS... 19.4 19.6 19.8 20	0.2	D= 6 ~ 9.8 → 32 10 ~15.8 → 35 16 ~20 → 40

型号例 Ex. **C10-6**

### 偏摆精度 Run-out accuracy

筒夹 Collet	偏摆精度(μm) Run-out accuracy (μm)
超精密级(P级) Precision collet	<b>5</b>
标准级 Standard collet	<b>10</b>

※筒夹单体的精度 Accuracy of collet alone.

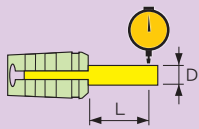

φD	L
~10	4×D
10~20	40

### 扳手 Spanner



CODE	刀柄型号 Holder type
<b>FC-36</b>	CTH10 CTA10
<b>-50</b>	CTH20 CTA20

### 可调节式扭矩扳手 Adjustable torque wrench

可更准确管理螺帽的拧紧扭矩。  
The nut-tightening torque can be adjusted more properly.

扭矩扳手头 Spanner for torque wrench  
可调节式扭矩扳手 Adjustable torque wrench



CODE	刀柄型号 Holder type
<b>FC-36AW</b>	AW-1
<b>-50AW</b>	-2

### 筒夹拔出器 Collet remover

可简单取出弹簧筒夹。  
The collet can be detached with ease.

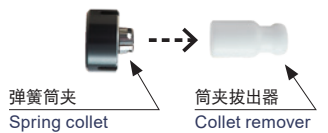

CODE	筒夹型号 Collet type
<b>C10-RM</b>	C10
<b>C20-RM</b>	C20

## 热装专用特殊钢材

### Specialized steel for the shrink-fit holder

- 热膨胀系数是一般钢材的1.6倍  
Its thermal expansion coefficient is 1.6 times higher than that of regular steel.
- 用温风式加热器即可进行热装卸操作  
Shrink fitting and removing is achieved using a hot-air heater.
- 不用担心加热过度  
Will not overheat even if heated for a long time.

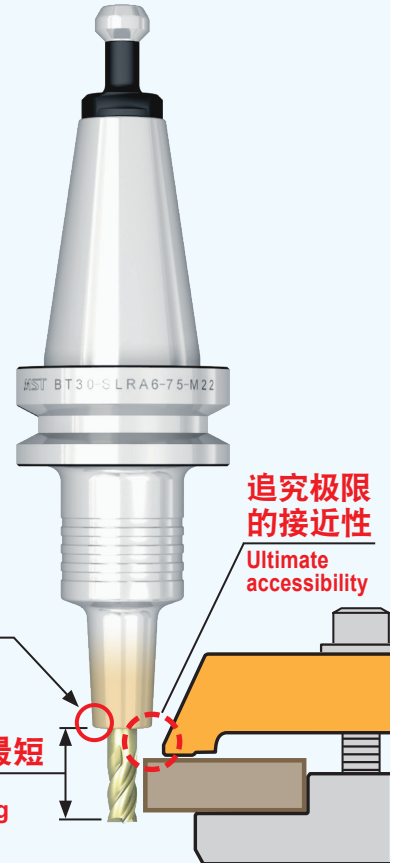

## 构造简单 & 细长设计

### Simple configuration & slim design

- 无零部件的一体式构造  
Simple and solid body configuration without any tightening parts for a tool.
- 前端壁厚仅为1.5mm的超纤细设计  
Ultra-slim design with 1.5mm tip thickness.
- 与工件无干涉, 可将刀具突出长度缩至最短  
Less interference with the work-piece with minimal the tool projection.
- 无论谁来操作都可实现高精度夹持  
Superior accuracy, regardless of who performs the shrinking operation.
- 丰富的刀柄产品种类  
A vast array of holders.
- 高夹持力不滑刀  
No tool slippage due to strong gripping force.

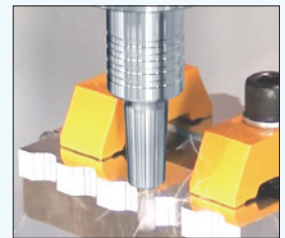

### 一体型系列 MONO series

一体型  
Integrated type



### 强力型 热装刀柄 HYPER VERSION

重切削用  
For heavy-duty  
machining



### 2体型系列 2 PIECE type

组合型  
Modular type

5 μm  
(12 type)

3 μm  
(6/8 type)

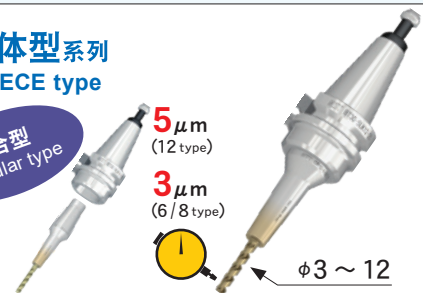

## 工件快速换装夹具系统 SMART GRIP

## Workpiece holder system SMART GRIP

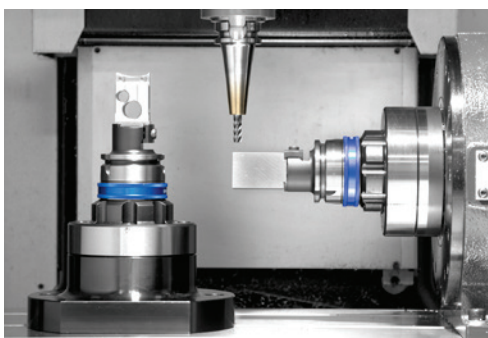

在3轴加工中心实现多面加工  
Multi-surface machining  
with 3-axis MC.

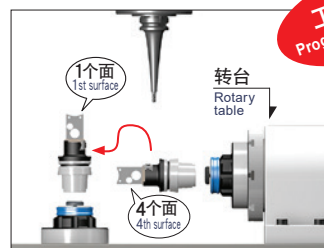

※详情请垂询弊司。 ※Contact us if you need it.



# 一体型系列

MONO series

## SLSA / SLRA

φ3 ~ 20

一体型 3°

一体型 曲线

CV

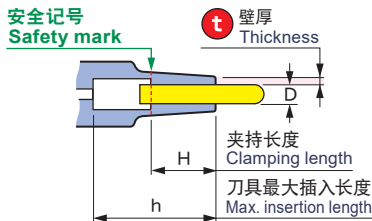
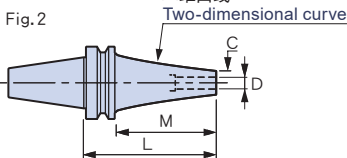
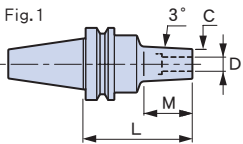

CODE	Fig.	φD	φC	t	L	M	H	h	Kg	
BT30-SLSA 3- 60-M22	1	3	6	1.5	60	22	9	80	0.4	
- 75-M22					75			99		
- 95-M42					95			42		119
-120-M67					120			67		144
-SLRA 3- 75-M22	1	3	7.5	3.25	75	22	9	99	0.5	
BT30-SLSA3.175-75-M22	1	3.175	6.175	1.5	75	22	9	99	0.4	
-95-M42					95			42		119
BT30-SLSA 4- 75-M22	1	4	7	1.5	75	22	12	99	0.4	
- 95-M42					95			42		119
-120-M67					120			67		144
-SLRA 4- 75-M22	1	4	10	3	75	22	12	99	0.5	
-SLSA 4- 75 CV	2	4	7	1.5	75	53	12	99	0.5	
- 90 CV					90			68		114
-120 CV					120			98		144
-SLRA 4- 90 CV	2	4	10	3	90	68	12	114	0.5	
-120 CV					120			98		144
BT30-SLSA 6- 75-M22	1	6	9	1.5	75	22	18	99	0.4	
- 95-M42					95			42		119
-120-M67					120			67		144
-SLRA 6- 75-M22	1	6	12	3	75	22	18	99	0.4	
-SLSA 6- 75 CV	2	6	9	1.5	75	53	18	99	0.5	
- 90 CV					90			68		114
-120 CV					120			98		144
-SLRA 6- 90 CV	2	6	13	3.5	90	68	18	114	0.5	
-120 CV					120			98		144
BT30-SLRA 8- 75-M22	1	8	14	3	75	22	24	99	0.4	
-SLSA 8- 75 CV	2	8	11	1.5	75	53	24	99	0.5	
- 90 CV					90			68		114
-SLRA 8- 90 CV	1	8	16	4	90	68	24	114	0.5	
BT30-SLRA10- 75-M22	1	10	16	3	75	22	30	99	0.4	
-SLSA10- 75 CV	2	10	13	1.5	75	53	30	99	0.5	
- 90 CV					90			68		114
-SLRA10- 90 CV	2	10	19	4.5	90	68	30	114	0.6	
BT30-SLRA12- 75-M22	1	12	20	4	75	22	30	99	0.5	
BT30-SLRA16- 60-M22	1	16	26	5	60	22	32	60	0.5	
BT30-SLRA20- 65-M22	1	20	32	6	65	22	38	60	0.6	

- 选购品 • 拉钉 → P.12
- 备考 • 如果带拉钉进行热装操作, 请使用通孔拉钉 (P-511)。如使用其他拉钉, 请在热装操作前取下拉钉。
- 注意事项 • 刀具安装... 插入刀具时, 请务必将刀具插入比安全记号更深的位置。
- Options • Retention knob → P.12
- Note • Use a retention knob with a hole (P-511). If using a retention knob without a hole, remove it during heating operation.
- Caution • Setting cutters... Be sure to insert the tool beyond the safety mark.

• 也可对应英制刀具。详情请垂询敝司。  
• We also produce cutters in inch sizes. Please contact us.

# 强力型 热装刀柄

HYPER VERSION

## 超短型

Short type

## SLRB S

φ10 ~ 16

刚性值 (μm/kgf)  
Rigidity value

60

↓

↓

↓

↓

↓

↓

↓

↓

↓

↓

↓

↓

↓

↓

↓

↓

↓

↓

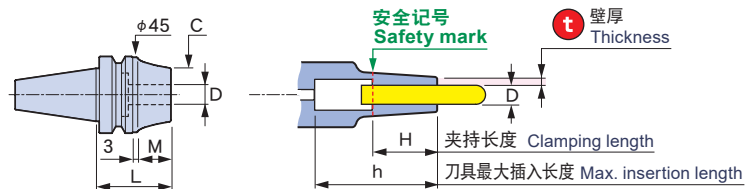

CODE	φD	φC	t	L	M	H	h	Kg	S
BT30-SLRB10S-45	10	28	9	45	20	21	68	0.5	0.4
-SLRB12S-45	12	32	10			22	61		0.3
-SLRB16S-45	16	38	11			25	57		

- 选购品 • 拉钉 → P.12
- 注意事项 • 加热装置请使用 HRB-03S-230AS (温风式) 或 HRD-02SH (电磁式)。
- 刀具安装... 插入刀具时, 请务必将刀具插入比安全记号更深的位置。
- Option • Retention knob → P.12
- Caution • As for MST SLIMLINE, please use HEAT ROBO Baby 3000S (HRB-03S-230AS) or HEATROBO DENJI 5000S (HRD-02SH).
- Setting cutters... Be sure to insert the tool beyond the safety mark.

# 2体型系列

2 PIECE type

6 type    8 type    12 type

**SLK 6**

φ3~6

**SLK 8**

φ3~8

**SLK 12**

φ3~12



本体

Master holder

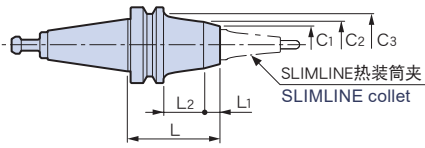

CODE	L	L1	L2	φC1	φC2	φC3	kg	
<b>BT30-SLK 6-35-MAS2</b>	35	13	—	19	—	34	0.5	6 type
<b>65-MAS2</b>	65	15	28		25.1		0.6	
<b>BT30-SLK 8-35-MAS2</b>	35	13	—	23	—	34	0.4	8 type
<b>-65-MAS2</b>	65	15	28		27.5		0.6	
<b>BT30-SLK 12-35-MAS2</b>	35	13	—	38	—	—	0.4	12 type

- 选购品    ● SLIMLINE 热装筒夹    ● 六角扳手 (6型8型通用)
- 标准附属品    ● 拉钉
- 备考    ● 标准附带后拉引导螺丝兼用的专用拉钉。  
关于拉钉的更换请垂询弊司。
- 注意事项    ● SLK12型请使用市售的14mm单口扳手拧紧。

- Option    ● SLIMLINE collet    ● Wrench (6 type · 8 type)
- Std. Access.    ● Retention knob
- Note    ● A dedicated retention knob is supplied as a standard accessory.  
To replace the extension knob, please contact us.
- Caution    ● To fasten the 12 type, use a commercially available 14 mm single-ended wrench.

## SLIMLINE 热装筒夹

SLIMLINE collet

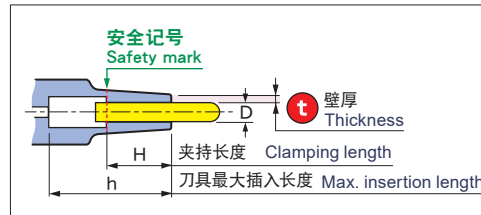
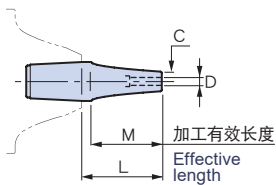

- 注意事项
- 刀具安装...插入刀具时,请务必将刀具插入比安全记号更深的位置。
- Caution
- Setting cutters...Be sure to insert the tool beyond the safety mark.

6 型

6 type

8 型

8 type

CODE	φD	φC	t	L	M	H	g	h
<b>CS6-3-15</b>	3	6	1.5	15	12	9	20	24
<b>-30</b>				30	27		30	39
<b>-45</b>				45	42		40	54
<b>CR6-3-30</b>	3	7.5	2.25	30	27	9	30	39
<b>-45</b>				45	42		40	54
<b>CS6-4-15</b>	4	7	1.5	15	12	12	30	24
<b>-30</b>				30	27			39
<b>-45</b>				45	42		40	54
<b>CR6-4-30</b>	4	10	3	30	27	12	30	39
<b>-45</b>				45	42		50	54
<b>CS6-6-15</b>	6	9	1.5	15	12	15	20	24
<b>-30</b>				30	27		30	35
<b>-45</b>				45	42		40	
<b>CR6-6-30</b>	6	12	3	30	27	15	20	35
<b>-45</b>				45	42			

CODE	φD	φC	t	L	M	H	g	h
<b>CS8-3-25</b>	3	6	1.5	25	22	9	60	37.5
<b>-45</b>				45	42		70	57.5
<b>-65</b>				65	62		80	77.5
<b>CR8-3-45</b>	3	7.5	2.25	45	42	9	70	57.5
<b>-65</b>				65	62		90	77.5
<b>CF8-3-45</b>	3	9.5	3.25	45	42	9	80	57.5
<b>-65</b>				65	62		100	77.5
<b>CS8-4-25</b>	4	7	1.5	25	22	12	60	37.5
<b>-45</b>				45	42		70	57.5
<b>-65</b>				65	62		80	77.5
<b>CR8-4-45</b>	4	10	3	45	42	12	80	57.5
<b>-65</b>				65	62		100	77.5
<b>CF8-4-45</b>	4	12	4	45	42	12	90	57.5
<b>-65</b>				65	62		110	77.5
<b>CS8-6-25</b>	6	9	1.5	25	22	15	60	35
<b>-45</b>				45	42		80	
<b>-65</b>				65	62		90	
<b>CR8-6-45</b>	6	12	3	45	42	15	90	35
<b>-65</b>				65	62		110	
<b>CF8-6-45</b>	6	14	4	45	42	15	100	35
<b>-65</b>				65	62		120	
<b>CS8-8-25</b>	8	11	1.5	25	22	20	60	37
<b>-45</b>				45	42		70	49
<b>CR8-8-45</b>	8	14	3	45	42	20	90	49
<b>CF8-8-45</b>	8	16	4	45	42	20	110	49

六角扳手 (6型8型通用)

Wrench (6 type · 8 type)

用于拧紧本体和SLIMLINE筒夹。 Used for clamping of main body and SLIMLINE collet mini.

CODE	Note
DW-14	6型8型通用 Both for 6 and 8 type



CODE	φD	φC	t	L	M	H	h	Kg
CS12-3- 35	3	6	1.5	35	22	10	60	0.2
- 55				55	42		80	
- 80				80	67		105	
-110				110	97		135	
CR12-3- 35	3	7.5	2.25	35	22	10	60	0.2
- 55				55	42		80	
- 80				80	67		105	
CF12-3- 35	3	9.5	3.25	35	22	10	60	0.2
- 55				55	42		80	
- 80				80	67		105	
CS12-3.175- 35	3.175	6.175	1.5	35	22	10	60	0.2
- 55				55	42		80	
- 80				80	67		105	
-110				110	97		135	
CS12-4- 35	4	7	1.5	35	22	12	60	0.2
- 55				55	42		80	
- 80				80	67		105	
-110				110	97		135	
CR12-4- 35	4	10	3	35	22	12	60	0.2
- 55				55	42		80	
- 80				80	67		105	
CF12-4- 35	4	12	4	35	22	12	60	0.2
- 55				55	42		80	
- 80				80	67		105	
CS12-5- 35	5	8	1.5	35	22	15	60	0.2
- 55				55	42		80	
- 80				80	67		105	
-110				110	97		135	
CS12-6- 35	6	9	1.5	35	22	18	60	0.2
- 55				55	42		80	
- 80				80	67		105	
-110				110	97		135	
CR12-6- 35	6	12	3	35	22	18	60	0.2
- 55				55	42		80	
- 80				80	67		105	
CRB12-6- 35	6	14	4	35	22	18	60	0.2
- 55				55	42		80	
- 80				80	67		105	
CF12-6- 35	6	14	4	35	22	18	60	0.2
- 55				55	42		80	
- 80				80	67		105	
CS12-7- 35	7	10	1.5	35	22	20	60	0.2
- 55				55	42		80	
- 80				80	67		105	
-110				110	97		135	

CODE	φD	φC	t	L	M	H	h	Kg
CS12- 8- 35	8	11	1.5	35	22	25	60	0.2
- 55				55	42		80	
- 80				80	67		105	
-110				110	97		135	
CR12- 8- 35	8	14	3	35	22	25	60	0.2
- 55				55	42		80	
- 80				80	67		105	
CRB12- 8- 35	8	18	5	35	22	25	60	0.2
- 55				55	42		80	
- 80				80	—		105	
CF12- 8- 35	8	16	4	35	22	25	60	0.2
- 55				55	42		80	
- 80				80	67		105	
CS12- 9- 35	9	12	1.5	35	22	30	60	0.2
- 55				55	42		80	
- 80				80	67		105	
-110				110	97		135	
CS12-10- 35	10	13	1.5	35	22	30	60	0.2
- 55				55	42		80	
- 80				80	67		105	
-110				110	97		135	
CR12-10- 35	10	16	3	35	22	30	60	0.2
- 55				55	42		80	
- 80				80	67		105	
CRB12-10- 35	10	22	6	35	22	30	60	0.2
- 55				55	—		80	
- 80				80	—		105	
CF12-10- 35	10	18	4	35	22	30	60	0.2
- 55				55	42		80	
- 80				80	—		105	
CS12-11- 35	11	14	1.5	35	22	30	60	0.2
- 55				55	42		80	
- 80				80	67		105	
-110				110	97		135	
CS12-12- 35	12	15	1.5	35	22	30	60	0.2
- 55				55	42		80	
- 80				80	67		105	
-110				110	—		135	
CR12-12- 35	12	20	4	35	22	30	60	0.2
- 55				55	42		80	
- 80				80	—		105	
CF12-12- 35	12	20	4	35	22	30	60	0.2
- 55				55	42		80	
- 80				80	—		105	

●也可对应英制刀具。详情请垂询敝司。 ●We also produce cutters in inch sizes. Please contact us.

刀柄台

Holder stand

SLIMLINE热装式筒夹、热装直柄延长杆、小径刀柄用安放台。共有4种颜色，方便分类整理。

This is a stand for SLIMLINE COLLETS, STRAIGHT arbor and compact holders. Selectable from four colors. Convenient to make arrangements by color-coding, etc.



Size: 190X190mm

CODE	颜色 Colors	正面 Front face	反面 Back face	放置个数 Storage capacity
SDKT-RE	Red	SLIMLINE热装筒夹	小径刀柄	各25支 25 pieces each
-BL	Blue	SLIMLINE collet	Small shank holder	
-GR	Green	热装直柄延长杆	(HSK-E25/E32)	
-GD	Gold	STRAIGHT arbor		



表面 Front face

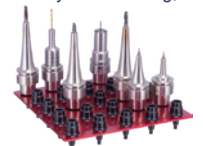

反面 Back face

在装夹刀具时，请勿超出刀具最大插入长度 (h)

如果刀具插入长度超过【刀具最大插入长度 (h)】，刀具柄部会与两体型本体的后拉引导螺丝碰触，导致无法安装筒夹。特别是φ3和φ4的插入长度较短，需要特别注意。由于热装筒夹的刀具插入长度较短，建议使用【热装刀柄用短柄铣刀】。

Be sure to insert the cutter shank to the max. insertion length (h).

If the cutting tool shank face touches the bottom of the holder, the collet will not be installed properly and it may cause poor accuracy. Be sure to pay attention to this by using CS6 and CS8 with L = 15 and 25, because their "h" dimension is very short. We recommend you use the short overall length tool for SLIMLINE because its insertion length is short.



热装刀柄用短柄铣刀  
Short-overall length end-mill for a shrink-fit holder



碰触 Interferes  
后拉引导螺丝 Draw bolt

# 热装装置 HEATROBO

## 电磁感应式加热器

## Induction Heater

### 电磁5000S Denji 5000S

加热 18秒 (φ6)  
Heating 18sec.

气体冷却 1分  
Air cooling 1 min

φ3 ~ 32

加热线圈 (选购品)  
Heating coil (Option)

气体冷却  
Air-cooling

适配器 (选购品)  
Adapter (Option)

底座 (选购品)  
Base (Option)



CODE	SIZE (W×D×H)	Voltage (三相) (3 phases)	KG
HRD-02SH	340×470×750	200-240v	30

#### 加热线圈 Heating coil

CODE	可对应刀柄孔径 Holder I.D
HRD2-CL1	φ3~ 6
-CL2	φ7~12
-CL3	φ16, 20
-CL6	强力型热装刀柄(超短型) HYPER VERSION (Short type)



### 电磁2500 Denji 2500

NEW

HRD-03LSE  
加热 25秒 (φ6)  
Heating 25sec.

气体冷却 1分  
Air cooling 1 min

φ3 ~ 16

HRD-03SSE  
加热 17秒 (φ6)  
Heating 17sec.

气体冷却 1分  
Air cooling 1 min

φ3 ~ 8

加热线圈 (标准附属品)  
Heating coil (Std. Access)

气体冷却  
Air-cooling



CODE	SIZE (W×D×H)	Voltage (单相) (Single phase)	KG
HRD-03LSE	340×470×750	200-240v	30
-03SSE			

### 电磁1200S Denji 1200S

加热线圈 (标准附属品)  
Heating coil (Std. Access)

加热 18秒 (φ6)  
Heating 18sec.

气体冷却 1分  
Air cooling 1 min

φ3 ~ 12

气体冷却  
Air-cooling



CODE	SIZE (W×D×H)	Voltage	KG
HRD-01S-230AS	230×540×550	230v	19

### 选购品 OPTIONS

#### 适配器 Adapter

#### 刀具防脱套 Cutter stopper

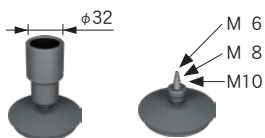

CODE	Note
ADH-BT30	一体型系列 MONO series
-SLK	SLIMLINE热装筒夹 SLIMLINE collet

#### 底座 Base

#### HSB (弹簧圈型) (Coil spring type)

#### HSC (槽孔筒夹型) (Slit collet type)

#### 底座 Base

#### HSB (弹簧片型) (Plate spring type)

CODE
BAA-01

Size: φ88×165mm



#### HSB (弹簧片型) (Plate spring type)

CODE	φD	数量 Q'ty
HSB-D	3, 3.175, 4, 5, 6, 7, 8, 9, 10, 11, 12, 16, 20	1个 1pc.
-E	3, 4, 6, 8, 10, 12	各1个 共计6个 6 pcs. in total with each one
-F	3, 4, 5, 6, 7, 8, 9, 10, 11, 12	各1个 共计10个 10 pcs. in total with each one
-EF	3, 4, 5, 6, 8, 10, 12, 16, 20, 25	铣刀柄径尺寸 各1个 共计10个 10 pcs. in total with each one (in end-mill size increments)

型号例 Ex. HSB - 6

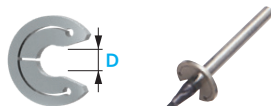

型号例 Ex. HSA - 3

■ 备考 ● 温风式加热器(HRB)用  
■ Note ● For HEAT ROBO Baby

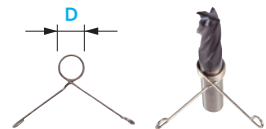

#### HSC (槽孔筒夹型) (Slit collet type)

CODE	φD
HSC-D	3, 3.175, 4, 6

型号例 Ex. HSC - 4





## 温风式加热器

## Hot Air Heater

### Baby 3000S

加热 70秒 (φ6)  
Heating 70sec.

气体冷却 5分  
Air cooling 5 min

φ3 ~ 32

还备有防止加热过度以及节省加热时间附带安全计时器的款式。

A type with a safety timer to prevent overheating and conserve energy is also available.

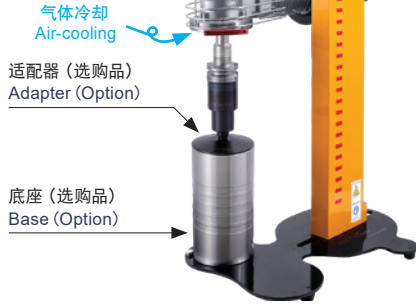
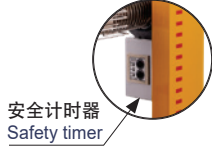

CODE	SIZE (W×D×H)	Voltage (单相) (Single phase)	重量 Kg
HRB-03S-230AS	430×330×660	230v	9.5

## 冷却操作台

## Shrink-fit Holder Chiller

### A型

### A type

CODE	冷却塔 Cooling Tower	重量 Kg
CWBA01	1个 1pc.	18
02	2个 2pcs.	25

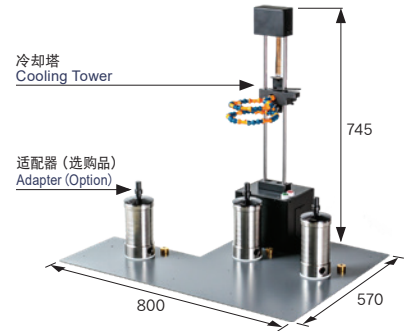

### B型

### B type

小巧型可安放于狭窄空间。  
Compact type that can be installed in tight spots.

CODE	重量 Kg
CWBB01	7.3

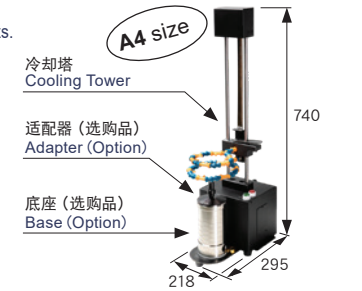

### C型

### C type

对于 HEAT ROBO Baby3000s  
For HEAT ROBO Baby 3000s

CODE	重量 Kg
CWBC01	7.2

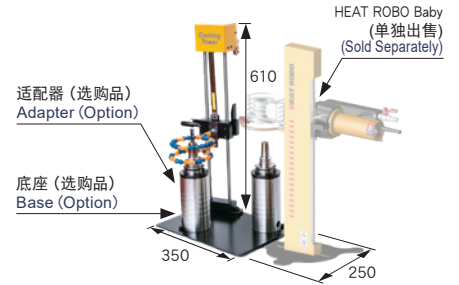

## 刀具长度调整器

## Cutter adjuster

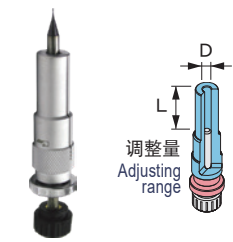

CODE	φD	L
HAI- 3	3	10~ 30
- 3.175	3.175	
- 4	4	13~ 30
- 6	6	19~ 45
- 8	8	21~ 55
-10	10	22~ 70
-12	12	23~ 85
-16	16	26~ 90
-20	20	37~100

## 刀具夹钳

## Cutter pliers

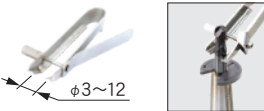

CODE
HPY-01

## 防脱套夹钳

## Stopper pliers



CODE
SPY-01

## 刀具冷却台

## Cutter tray



CODE
SDH-01

Size:  
170×170mm

## 清洁用具

## Cleaning tool

### 橡胶磨石型

### Rubber grinding stone type



### 握柄

### Grip

CODE
CLT-GTA-GP

### 橡胶磨石

### Rubber grinding stone

CODE	φd	数量 Q'ty
CLT-GTA 3-5	3	5
-GTA 4-5	4	5
-GTA 6-5	6	5
-GTA 8-5	8	5
-GTA10-5	10	5

### 标准组套

### Standard set

CODE	数量 Q'ty
CLT-GTA-01	右边的配件各1个 1 ea. for right model

### 清洁刷

### Brush type



CODE	φd	数量 Q'ty
AQC-BR-SET	3, 4, 6, 8, 10, 12	各1个 Each 1 set
-BR 3-5	3	5
-BR 4-5	4	5
-BR 6-5	6	5
-BR 8-5	8	5
-BR10-5	10	5
-BR12-5	12	5

# 袖珍型角度头

# ANGLE HEAD HALF

外形小巧可进行ATC自动换刀

Its compact and lightweight body achieves using A.T.C.

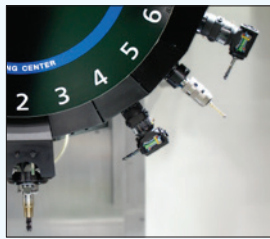

90°型  
90° type

φ1 ~ 10  
M2 ~ 8

1.8 kg



丝锥用  
For tapping



钻头用  
For drilling



迷你型  
mini type

φ3, 4, 6  
M4, 5, 6

万向型  
Universal type

φ1 ~ 7  
M2 ~ 8

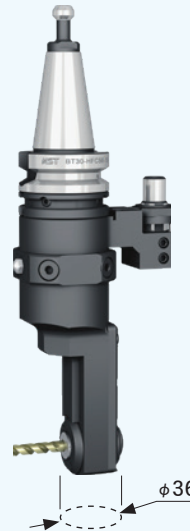

## 90°型

## 90° type

Fig. 1

HFD

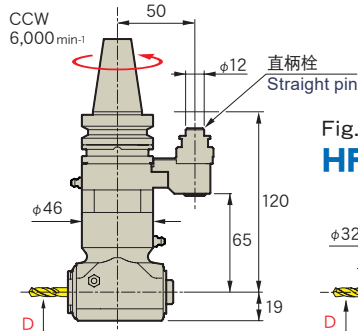

Fig. 2  
HFA

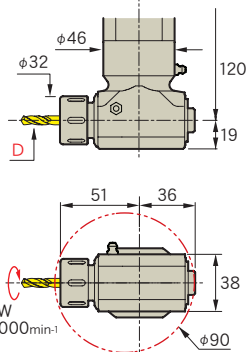
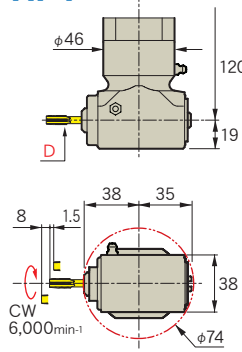

Fig. 3  
HFT



CODE	Fig.	φD	Kg	
BT30-HFD7L-120-s50c	1	1 ~ 7	1.8	D 7
-HFA10-120-s50c	2	2.4~10		C10
-HFT4L-120-s50c	3	M2 ~ 8		TA4

- 选购品
  - DETa-1超弹性弹簧筒夹(HFD)→P.2
  - 弹簧筒夹(HFA)→P.3
  - 丝锥筒套(HFT)
  - 拉钉→P.12
- 标准附属品
  - 辅助扳手(HFD/HFT)
  - 六角扳手套装
  - 单口扳手
  - 挂钩扳手(HFA)
- Option
  - DETa-1 Collet (HFD)→P.2
  - Spring collet(HFA)→P.3
  - Tap sleeve(HFT)
  - Retention knob→P.12
- Std. Access.
  - Fixing spanner (HFD/HFT)
  - Hexagonal wrench set
  - Single ended Spanner (HFD/HFA)
  - Spanner(HFA)

## DETa-1 超弹性弹簧筒夹 DETa-1 collet

P. 2



## 弹簧筒夹

## Spring collet (C10)

P. 3



## 丝锥筒套

## Tap sleeve

CODE	φD
TA4-M2	M2, M2.6
-M3	M3
-M4	M4
-M5	M5
-M6	M6
-M8	M8



## 定位块

## Positioning block

CODE	NOTE
ABF213	S300Xd1 / X1N / X2 / X1 S500Xd1 / X1N / X2 / X1 S700Xd1 / X1N / X2 / X1
ABF259	W1000Xd2 / Xd1 S1000X1 / X1N



- 注意事项
  - 如果上表格内无贵司所使用的机床型号,请垂询敝司。
  - S300的部分机型,根据90°型和万向型角度头的加工角度,超过了机床容许的最大刀具长度,因此无法使用。请检查确认您所使用机床的最大刀具长度或联系我们。
- Caution
  - Please contact us for models not listed above.
  - S300, some models cannot be used depending on machine specifications. Please confirm the max tool length of machine or contact us.

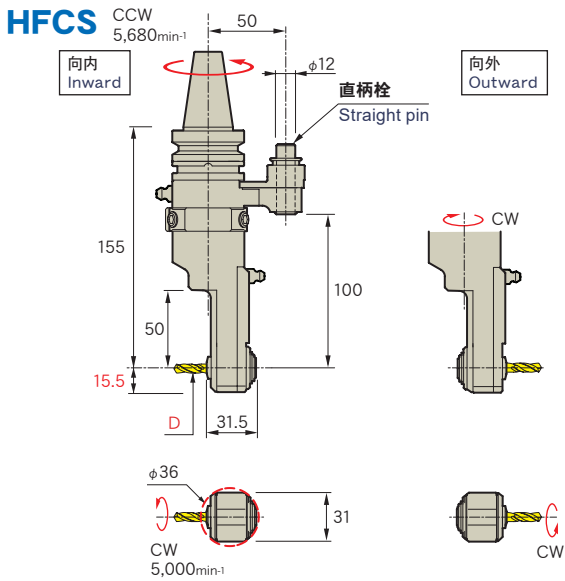

CODE	φD	Kg
BT30-HFCS6-155-s50c	3, 4, 6, M4, M5, M6	1.8

- 选购品 ●热装筒夹 ●丝锥筒夹 ●拉钉→P.12
- 标准附属品 ●辅助扳手 ●六角扳手套装
- 注意事项 ●刀具向内和向外时主轴的旋转方向不同。 ●S300型机床根据款式不同,部分尺寸无法使用。
- Option ●Shrink-fit collet ●Tap collet ●Retention knob→P.12
- Std. Access. ●Fixing spanner ●Hexagonal wrench set
- Caution ●The angle axis rotating direction is different due to its mounting direction, inward and outward. ●S300, some models cannot be used depending on machine specifications.

热装筒夹

Shrink-fit collet

丝锥筒夹

Tap collet

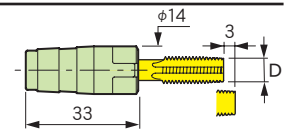
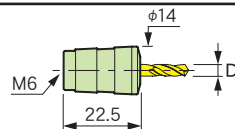

CODE	φD	夹持长度 Holding length
FCS6-3	3	11~13
-4	4	
-6	6	12~13

CODE	φD	夹持长度 Holding length
FCS6-M4	M4	16
-M5	M5	
-M6	M6	

- 备考 ●硬质合金刀具专用 ●夹持刀具需要使用加热器。→P.8
- Note ●The dedicated shrink-fit collet for the Angle Head Half, Mini. ●A shrink-fit heating device is required to insert and remove cutting tools.→P.8

万向型

Universal type

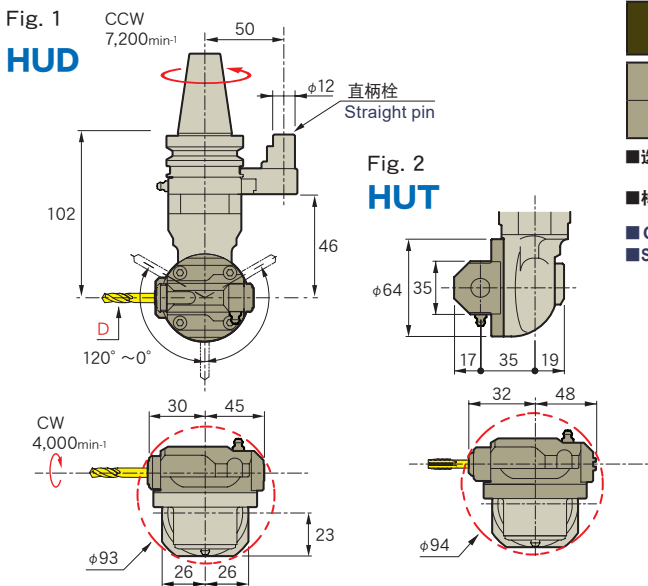

CODE	Fig.	φD	刀径	Kg
BT30-HUD7-102-s50c	1	1~7	D 7	1.8
-HUT4-102-s50c	2	M2~8	TA4	

- 选购品 ●DETa-1超弹性弹簧筒夹(HUD)→P.2 ●丝锥筒套(HUT)
- 拉钉→P.12
- 标准附属品 ●辅助扳手(HUD) ●六角扳手套装
- Option ●DETa-1 Collet (HUD)→P.2 ●Tap sleeve(HUT) ●Retention knob→P.12
- Std. Access. ●Fixing spanner (HUD) ●Hexagonal wrench set

面铣刀柄

FACE MILL ARBOR

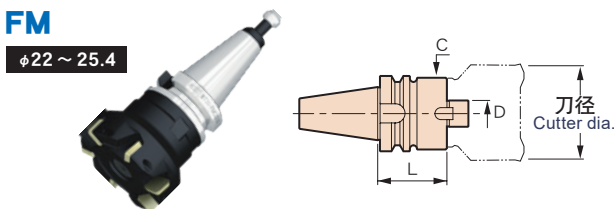

CODE	刀径 Cutter dia.	φD	L	φC
BT30-FMC22 -30	50/63/80	22	30	45
-FM22.225 -30	50	22.225		
-FMA25.4 -45	76	25.4	45	50

- 选购品 ●拉钉→P.12
- 标准附属品 ●紧固螺栓
- 备考 ●FMA25.4的紧固螺栓,根据刀盘形状,有可能需要使用M12内六角螺栓。
- Options ●Retention knob→P.12
- Std. Access. ●Clamp bolt
- Note ●In some cases, FMA25.4 may require a hexagonal socket bolt with M12 depending on cutter sizes.

NEW

# 可换式刀具用 铣镗刀柄 MILL BORE

# Indexable End-Mill Arbor MILL BORE

最适合螺旋铣镗加工!  
Optimum tool holder for helical boring!

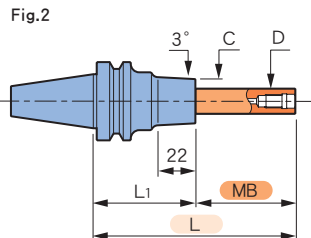
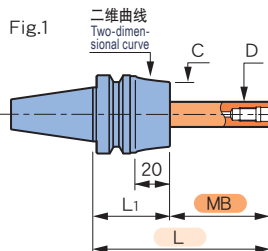
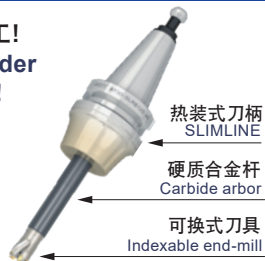

CODE	Fig.	L1	φC	MB	φD	L	刀径 Cutter dia.
BT30-SLRB16S -45-MB25	1	45	38	25	15	70	16
				50		95	
				75		120	
BT30-SLRA16 -60-M22-MB 25	2	60	26	25	15	85	16
				50		110	
BT30-SLRA20 -65-M22-MB 25	2	65	32	25	19	90	20
				50		115	
				75		140	

可换式刀具 安装位置

Dimensions of mounting area for an Indexable tool

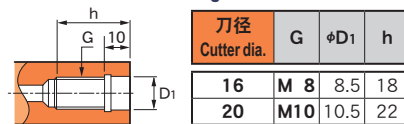

刀径 Cutter dia.	G	φD1	h
16	M 8	8.5	18
20	M10	10.5	22

- 选购品
- 注意事项
- Option
- Caution
- 拉钉
- 也会有一部分无法安装的可换式刀具。详情请垂询敝司。
- Retention knob
- Some of an indexable tool cannot be mounted. For details, please contact us.

## 周边设备

## Peripherals

### 机床主轴维护保养用 测试棒

For machine spindle maintenance Test bar

主轴测试棒 CHECKMATE

CHECKMATE

CODE	L	Kg
NT30-CMA20-125	125	0.7
-CMB30-175	175	1.0

加工前简单测量机床主轴偏摆精度。  
Ideal for checking machine spindle run-out accuracy easily before machining.



### 设定Z轴原点/测量基准位置用工具 Z axis origin setting tool

Goo测量仪

Goo CHECKER

CODE	L	Kg
BT30-ZPM-130	130	1.0
-165	165	1.2

可轻松确认并设置工件原点(Z点)。  
It set up the original point of work-piece in M/C.

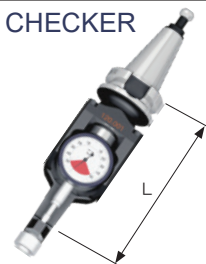

### 刀具紧固台

Tool tightening stand

锁刀座

Tool set up stand

CODE	Kg
HF-BT30	0.8

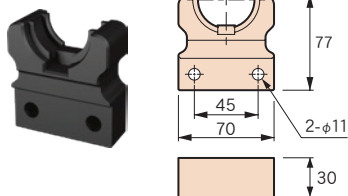

### 主轴锥孔用 清洁工具

For a spindle taper hole, Cleaning tool

主轴清洁棒 STAR DUST

STAR DUST

CODE
CLT-NT30-G2

用于清洁机床主轴。  
※也备有用于清洁刀柄的款式。  
详情请垂询敝司。  
Use when cleaning the machine spindle taper.  
※A tool for the holders is also available.  
Please contact us.



### 刀具保护盒

Cutter protection box

铣刀小管家

ENDMILL HOUSE

CODE
EMO-SET-01

通过最佳刀具管理方式,节约刀具费和作业时间。  
Save cutting tool expenses and time with the optimum working environment.

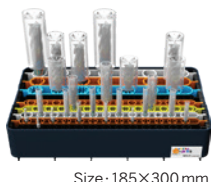

Size: 185×300 mm

### 筒夹托盘

### 刀具保护套

PALETTE

TOOL CAP

Collet stand  
PALETTE

Cutting tool cover  
TOOL CAP

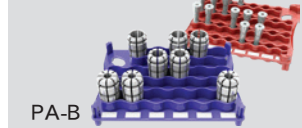

### Retention knob

### 拉钉



CODE	φd	φD	Note
P30T-2	-	7	-
P-511	2.5	7.5	中心通冷主轴用※ Coolant-through※
P-494	3.7	7	DTB 3用 For DTB 3
P-535	2.5	7.5	DTB12用 For DTB12

※一体式热装式刀柄进行热装操作时,请拆下拉钉,或使用带通孔拉钉(P-511)。  
DTB3刀柄如果配合带通孔拉钉(P-494)使用,无需拆下拉钉即可实现筒夹的安装与拆卸。  
DTB12型的拉钉(P-535)为后拉螺栓一体型专用拉钉。拧紧时请选用市售的单口扳手(13mm)。  
※Remove a retention knob or use a coolant through type (P-511) at the shrink operation of mono block type.  
When using the retention knob with hole (P-494) for DTB3 collet can be attached and detached without removal of retention knob.  
DTB12 requires the dedicated retention knob(P-535), which has the feature of draw bolt. Please use a commercially available 13mm single-ended wrench.